

附逆止閥中實迴轉油壓缸

ROTATING HYDRAULIC CYLINDER WITH SAFETY DEVICE

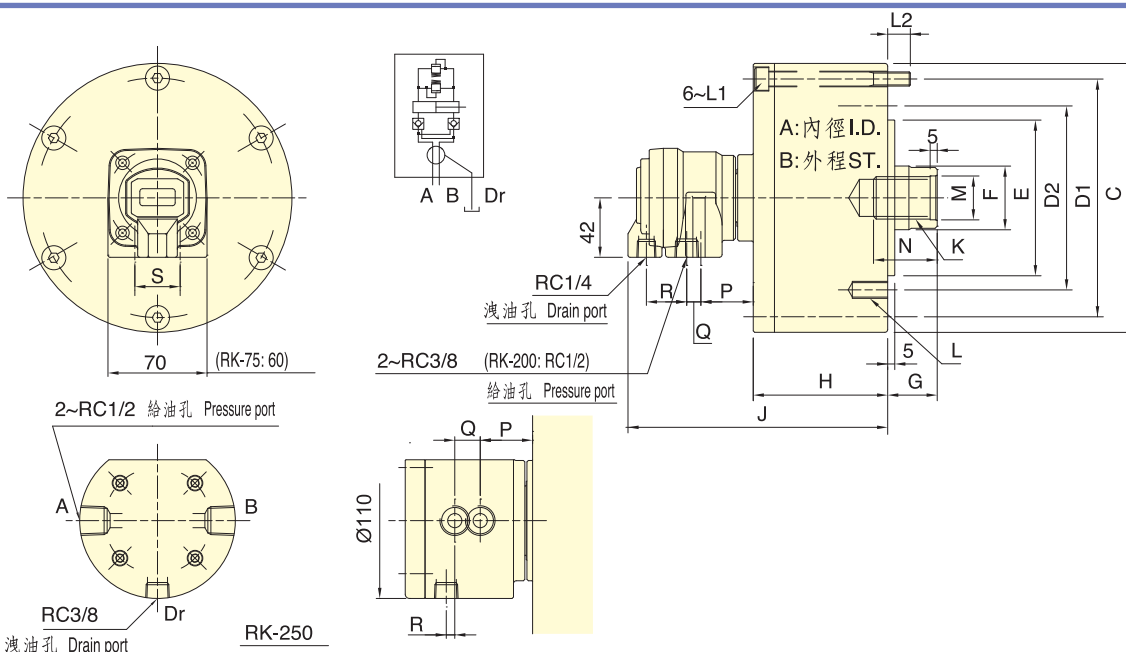

- 短型，高速，輕量型迴轉油壓缸。
- 內建逆止閥自鎖機構及壓力洩壓閥。
- 安裝時可由後端鎖固之。
- For short form, light weight and high speed rotary cylinder.
- Built-in safety check valves and pressure relief valves.
- Can screw it from the rear end of the cylinder when mounting.
- 洩油孔配管務必單獨接回油壓槽，以避免產生背壓。
- The drain port should be independently connected to oil tank to avoid back pressure.



保留規格修改的權利
Subject to technical changes.

規格 Spec. 型號 Model	活塞面積 Eff. piston area cm ²		行程 mm Piston stroke	最高迴轉數 min ⁻¹ (r.p.m) Max. speed	最高使用壓力 MPa Max. pressure (kgf/cm ²)	I kg·m ² Moment of inertia	重量 kg Weight
	押側 Extend	拉側 Retract					
RK-75	44.2	37.1	15	6000	4.0 (40)	0.01	2.9
RK-100	78.5	71.5	20			0.03	4.4
RK-125	122.7	113.1	25	0.05		6.9	
RK-150	176.7	160.8	30	0.09		9.5	
RK-200	314.1	290.4	35	0.28		15.4	
RK-250	469.1	436.0	60	2000	5.0 (50)	0.40	45.2

寸法 Size 型號 Model	A	B	C	D1	D2	E	G		H	J	K	L	L1	L2	M	N	P	Q	R	S
					h7		max.	min.							H8					
RK-75	75	15	107	90	65		30	45	30	57	148	6~M8x16	M8x60						27.5	26
RK-100	100	20	132	115	100	80				72	163	6~M10x20	M8x75	12	21	35	39.5	10		
RK-125	125	25	160	140	130	110	35	50	25	82	172	6~M12x20	M8x85		25		38.5			
RK-150	150	30	190	170			45	55		95	184	12~M12x24	M10x100	16	32	45	37		28.5	
RK-200	200	35	245	220	145	120	55	70	35	115	201	12~M16x30	M10x125	21	38	60	38	6		28
RK-250	245	60	307	275	220	160	65	85	25	165	255	12~M20x35	M16x175	28	45	65	33	18	6	-